

SERVO-TEK®

SERVO-TEK PRODUCTS COMPANY, INC.

DC Tachometer Generators



Technical Data

An Industry Standard for over fifty years.

A Servo-Tek DC tachometer generator provides a convenient and economical means of converting rotational speed into an isolated analog voltage signal suitable for remote indication and control. While this catalog contains information on our most popular models, we also manufacture countless special tach generators.

Construction

Most of our DC tach generators are housed in aluminum casings protected in accordance with Mil-C-5541 or Mil-A-8625 or high performance plastics. Alnico permanent magnets are used. Armature shafts are stainless-steel, and rotate on fully shielded stainless-steel ball bearings. Commutators are manufactured from an alloy containing at least 90% silver. Armature laminations are wound with Isomid insulated wire, over Teflon slot insulation. The entire armature is then baked, resulting in a NEMA Class H insulation system.



Ripple

The ripple RMS value will not exceed 3% of the DC value at any speed in excess of 40 RPM on standard units. On the low ripple units, the ripple RMS value will not exceed 1.5% of the DC value. A peak to peak ripple of 1.5% is available on some models.

Linearity

Linearity at any speed is better than 0.1% of the output at that RPM.

Bidirectional Operation

All Servo-Tek tachometer generators operate in either rotational direction. That direction can be determined by output voltage polarity. Output (in either direction) is held to a tolerance of 0.25% of the average output.



Stability

Optimum brush and commutator combination gives 0.1% stability. Highly stable output gives no evidence of long-term drift.

Breakdown Voltage

Servo-Tek DC tachometer generators are factory tested with an AC potential of 1250 volts RMS applied for one second between (either) terminal and shaft. E-Series units are tested with 500 volts.

Temperature Range

Most of our DC tachometer generators are designed for continuous operation in ambient temperatures ranging from -55°C to +100°C. Voltage output at 25°C will not deviate by more than 0.01% per degree of change within the range of -20°C to +75°C. All units are temperature compensated, with the exception of D-Series and E-Series tach generators.

A-Series 1 to 10 volts/1000 RPM



A-Series Tachometer Generators

Instrument Type:

- 0.120 inch shaft diameter
- Small in size
- Ideally suited to instrumentation applications

Industrial Type:

- 0.187 inch shaft diameter
- Special front-end bearings for radial loads
- Ideal for pulley and belt drive applications

B-Series 11 to 24 volts/1000 RPM



B-Series Tachometer Generators

As is the case with the A-Series DC tachometer generator, the B-Series also comes in instrument and industrial configurations. Depending on the unit, the output voltage ranges between 11 and 24 V/1000 RPM. Electrical characteristics, ripple, linearity and temperature effects are the same as the A-Series.

Other shaft sizes and mounting configurations are available for most Servo-Tek generators.

A-Series and B-Series Specifications

Model Number	Mounting	Weight (Approx.)	Inertia (Approx.) oz-in-sec ²	V/1000 RPM	RPM (max)	Armature Resistance (dynamic)	Armature Inductance (henrys)	Outline Dimensions	Mounting Dimensions	Shaft Size (in.)
SA-740A-7	Face	3.0 oz	1.32 x 10 ⁻⁴	2.6v	12,000	40Ω	0.024h	Fig. 10	Fig. 1	.120
SB-740A-7	Flange	3.0 oz	1.32 x 10 ⁻⁴	2.6v	12,000	40Ω	0.024h	Fig. 10	Fig. 2	.120
SA-740A-2	Face	3.0 oz	1.32 x 10 ⁻⁴	7.0v	12,000	350Ω	0.18h	Fig. 10	Fig. 1	.120
SB-740A-2	Flange	3.0 oz	1.32 x 10 ⁻⁴	7.0v	12,000	350Ω	0.18h	Fig. 10	Fig. 2	.120
SA-757A-2	Face	3.0 oz	1.32 x 10 ⁻⁴	7.0v	12,000	350Ω	0.18h	Fig. 11	Fig. 1	.187
SB-757A-2	Flange	3.0 oz	1.32 x 10 ⁻⁴	7.0v	12,000	350Ω	0.18h	Fig. 11	Fig. 2	.187
SA-740B-1	Face	4.0 oz	2.27 x 10 ⁻⁴	20.8v	8,000	1000Ω	0.56h	Fig. 10	Fig. 1	.120
SB-740B-1	Flange	4.0 oz	2.27 x 10 ⁻⁴	20.8v	8,000	1000Ω	0.56h	Fig. 10	Fig. 2	.120
SA-757B-1	Face	4.0 oz	2.27 x 10 ⁻⁴	20.8v	8,000	1000Ω	0.56h	Fig. 11	Fig. 1	.187
SB-757B-1	Flange	4.0 oz	2.27 x 10 ⁻⁴	20.8v	8,000	1000Ω	0.56h	Fig. 11	Fig. 2	.187

Maximum Driving Torque for A-Series and B-Series is 0.25 oz-in
 Most units listed above are normally in stock

D-Series 25 to 50 volts/1000 RPM



SU-780D-1

D-Series Tachometer Generators

With rugged construction and high output voltages, the D-Series tach generator is ideally suited to a variety of industrial applications.

The flange mounting arrangement provides a convenient assembly method, and the sturdy .187 shaft diameter permits the heavier loading frequently encountered where pulleys or belt drives are employed. The output bearing is fitted with a seal to help prevent the contamination that can occur in industrial applications.

With output up to 50V/1000 RPM, D-Series generators are ideal for applications where high output voltages are required. Typically, these are slow speed applications.

E-Series (Subminiature) .7 to 3 volts/1000 RPM



SS-779E-1

E-Series Tachometer Generators

The E-Series DC tachometer generator is the smallest tach generator among those offering similar technical characteristics. Many outstanding features make it particularly suitable for use in all types of servo systems. Although the diameter is only 0.760" the E-Series provides up to 3 V/1000 RPM output.

Almost any Servo-Tek DC tachometer generator can be manufactured with special configurations, various electrical specs and shaft modifications such as flats, pinions, holes, etc. Consult sales department regarding your special requirements.

D-Series and E-Series Specifications

Model Number	Mounting	Weight (Approx.)	Inertia (Approx.) oz-in-sec ²	V/1000 RPM	RPM (max)	Armature Resistance (dynamic)	Armature Inductance (henrys)	Outline Dimensions	Mounting Dimensions	Shaft Size (in.)
SU-780D-1	Flange	8.5 oz	4.54 x 10 ⁻⁴	45v	5,000	1750Ω	1.00h	Fig. 10	Fig. 5	.187
SU-7114D-1	Flange	8.5 oz	4.54 x 10 ⁻⁴	45v	5,000	1750Ω	1.00h	Fig. 10	Fig. 5	.187
SU-780D-2	Flange	8.5 oz	4.54 x 10 ⁻⁴	33v	5,000	950Ω	0.54h	Fig. 10	Fig. 5	.187
SS-779E-1	Synchro	1.25 oz	0.25 x 10 ⁻⁴	3v	12,000	180Ω	0.061h	Fig. 12	Fig. 6	.120

Maximum Driving Torque for D-Series and E-Series is 0.25 oz-in
 Most units listed above are normally in stock

Low Ripple Units (F-Series, H-Series and J-Series) 1 to 30 volts/1000 RPM



F-Series (1-8 volts/1000 RPM)

Servo-Tek low ripple DC tachometer generators satisfy the need for a cost effective, very low ripple tachometer. In addition to being the first economical low ripple units of their type, the F-Series tachometers incorporate all the desirable features of the standard units such as temperature compensation, long brush life, excellent linearity, and small dimensions.

The ripple voltage does not exceed 1.5% RMS and 3.5% peak to peak at any speed in excess of 40 RPM on any F-Series, H-Series or J-Series DC tachometer generator.

H-Series (5-16 volts/1000 RPM)

The H-Series DC tachometer generators are low ripple units possessing all the same traits as the F-Series, but with the B-length armature. This means a slightly higher output voltage.

J-Series (16-30 volts/1000 RPM)

The J-Series DC tachometer generators are low ripple units possessing all the same traits as the F-Series, but with the D-length armature. These generators are ideal for applications where high output voltages with low ripple signals are required.

Other shaft sizes and mounting configurations are available.

F-Series, H-Series and J-Series Specifications

Model Number	Mounting	Weight (Approx.)	Inertia (Approx.) oz-in-sec ²	V/1000 RPM	RPM (max)	Armature Resistance (dynamic)	Armature Inductance (henrys)	Outline Dimensions	Mounting Dimensions	Shaft Size (in.)
SA-7356F-1	Face	3.0 oz	1.14 x 10 ⁻⁴	7.0v ± 3%	12,000	500Ω	0.38h	Fig. 10	Fig. 1	.120
SA-7388F-1	Face	3.0 oz	1.32 x 10 ⁻⁴	7.0v ± 3%	12,000	500Ω	0.38h	Fig. 10	Fig. 1	.187
CS-7514F-51C	Flange	3.0 oz	1.32 x 10 ⁻⁴	3.0v ± 3%	12,000	130Ω	0.061h	Fig. 11	Fig. 3	.250
SB-7483H-1	Flange	4.0 oz	1.96 x 10 ⁻⁴	16.0v ± 3%	8,000	800Ω	0.72h	Fig. 11	Fig. 2	.187
SU-780J-1	Flange	8.5 oz	4.54 x 10 ⁻⁴	30v ± 1%	5,000	1050Ω	1.00h	Fig. 10	Fig. 5	.187

Maximum Driving Torque for F-Series, H-Series and J-Series is 0.25 oz-in at 25°C
Most units listed above are normally in stock

Sealed DC Tachometers 1 to 45 volts/1000 RPM



ST-7337A-2N and ST-7337B-1

Sealed Tachometer Generators

Servo-Tek manufactures a complete line of sealed units which are resistant against the harmful effects of fluids. These units employ a one-piece housing, a special shaft seal, and a form-fitted rubber boot on the terminal end. Servo-Tek sealed units meet electrical specifications after storage at 49°C with 95% relative humidity for 24 hours. These units are capable of enduring vibration with amplitudes up to 0.03" total excursion at frequencies from 4 Hz to 55 Hz in each of three mutually perpendicular axes with no evidence of physical damage. These units are available with a low ripple output up to 30V/1000 RPM.

Servo-Tek's Ruggedized PY Alternative (Up to 50 volts)



ST-13212 and ST-12970

Ruggedized Tachometer Generators

Servo-Tek ruggedized DC tachometer generators are designed with sturdy aluminum housings and strong mounting flanges. Other features offered include extra-heavy armature shafts and bearings. The mechanical flexibility of the ST-13212 allows for the internal tachometer to be repaired or replaced, without having to replace the expensive anodized casting. The ST-13212 supplies outputs from 2.6 to 50V/1000 RPM and runs at speeds up to 5000 RPM. The shaft size is 5/16" in diameter. The ST-12970 comes equipped with a rubber coupling. It allows the unit to be driven by a motor shaft with 0.167" wide slot. The ST-12970 is also available with outputs up to 24V/1000 RPM and can run at high speeds.

Sealed DC Tachometer Generator Specifications

Model Number	Mounting	Weight (Approx.)	Inertia (Approx.) oz-in-sec ²	V/1000 RPM	RPM (max)	Armature Resistance (dynamic)	Armature Inductance (henrys)	Outline Dimensions	Mounting Dimensions	Shaft Size (in.)
ST-7336A-7	Face	3.0 oz	1.32 x 10 ⁻⁴	2.6v	12,000	40Ω	0.024h	Fig. 8	Fig. 8	.120
ST-7336A-2	Face	3.0 oz	1.32 x 10 ⁻⁴	7.0v	12,000	350Ω	0.18h	Fig. 8	Fig. 8	.120
ST-7336B-1	Face	4.0 oz	2.27 x 10 ⁻⁴	20.8v	8,000	1000Ω	0.56h	Fig. 8	Fig. 8	.120
ST-7337A-2	Face	3.0 oz	1.32 x 10 ⁻⁴	7.0v	12,000	350Ω	0.18h	Fig. 8	Fig. 8	.187
ST-7337B-1	Face	4.0 oz	2.27 x 10 ⁻⁴	20.8v	8,000	1000Ω	0.56h	Fig. 8	Fig. 8	.187
SU-7346D-1	Flange	8.5 oz	4.54 x 10 ⁻⁴	45v	5,000	1750Ω	1.00h	Fig. 8	Fig. 5	.187

Maximum Driving Torque for a sealed DC tachometer generator is 0.7 oz-in
Most units listed above are normally in stock

Overhung Tachometer 1 to 24 volts/1000 RPM

ST-7565 Series

Introducing Servo-Tek's new low-cost overhung tachometer. This bearingless tach-generator is small in size and has a black delrin housing and end plate. Because the Servo-Tek overhung unit is self-generating and provides an analog output, it makes for an excellent alternative to the encoder. No D-A conversion will be necessary! Mounts easily using a 10-32 threaded shaft. No coupling or mounting brackets will be required.



Part Number: **ST-7565A-2**

Output Voltage: 7 VDC \pm 5%, no load, per 1000 RPM at 25°C

Internal Resistance: 270 Ohms typical at 25°C

Ripple: 5% RMS of DC output voltage at speeds over 40 RPM

Linearity: 0.1% max., 0 to 4000 RPM

Bidirectional Output: 0.5% of nominal output in both CW and CCW directions

Polarity: Red wire positive with CCW rotation viewing shaft end

Temperature Coefficient: 0.05% per °C of nominal output at 25°C from -20°C to 50°C

Accessories



ST-9502

Rubber Couplings

ST-9502-1 fits .120 shafts and ST-9502-2 fits .187 shafts. The tapered tang is molded to fit a straight slot 0.167" \pm .005" wide and 3/16" deep.



ST-9776

Flexible Couplings

ST-9776 fits shaft diameters of up to .375 shafts. They may be ordered in any mixed or matched configuration. **When ordering, please specify both hole sizes.**

Other Products



ST50

ST50 Optical Encoder

The ST50, a 2 inch hollow shaft encoder, accepts motor shafts from .236 to .625 inches OD. It combines 3 phase brushless commutation pulses, 2 data channels and reference index pulse in a single package.



ST20

ST20 Optical Encoder

The ST20, a 2 inch shaft encoder, is a low cost, heavy duty solution to digital feedback. This unit is available in single or dual channel with nearly unlimited mounting patterns.

Mounting and Outline Dimensions

Figure 1 SA Face Mount

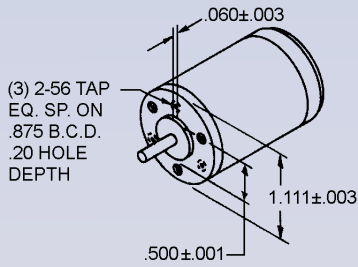

Figure 2 SB Flange Mount

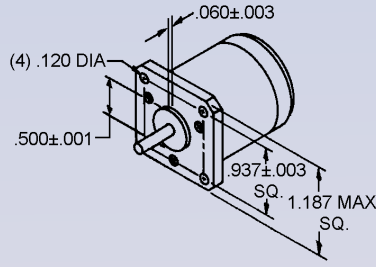

Figure 3 SD Modified Synchro

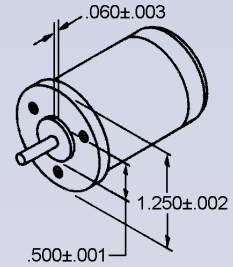

Figure 4 SM Aircraft Mount

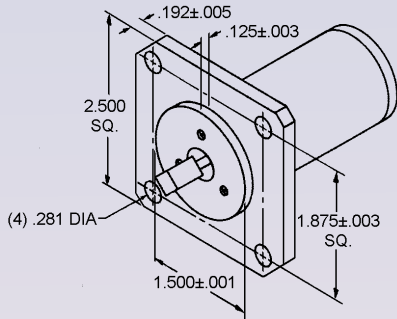

Figure 5 SU Large Flange Mount

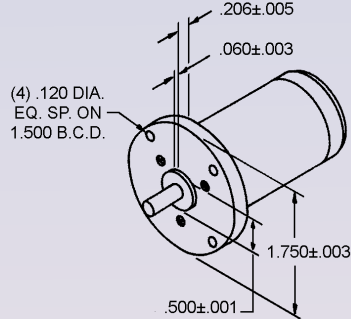

Figure 6 SS Synchro Mount

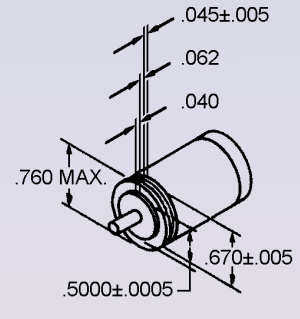
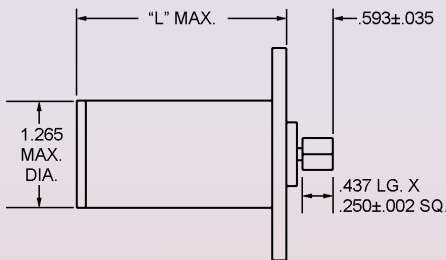
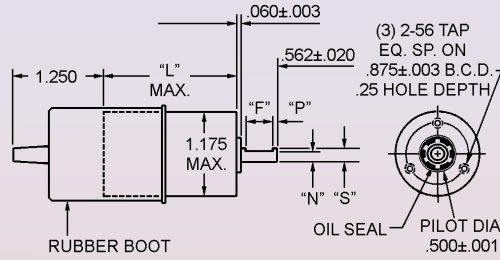

Figure 7 Aircraft Configuration



Model #	"L"
SM-762A	2.520
SM-762B	2.957

Figure 8 Sealed Configuration



Model	"L"	"F"	"P"	"N"	"S"
ST-7336A	1.867	OMIT	OMIT	OMIT	0.120 ± .001
ST-7336B	2.304	OMIT	OMIT	OMIT	0.120 ± .001
ST-7337A	1.875	0.375	0.062	0.157	0.187 ± .001
ST-7337B	2.312	0.375	0.062	0.157	0.187 ± .001
XX-7346D	3.633	0.375	0.062	0.157	0.187 ± .001

Figure 9 Flat Shaft Configuration

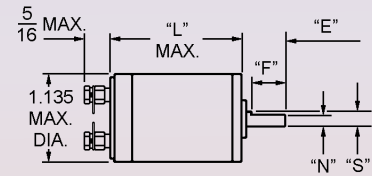

Model	"L"	"E"	"F"	"N"	"S"
XX-7114B	2.193	0.562	0.437	0.157	0.187 ± .001
XX-7114D	3.253	0.562	0.437	0.157	0.187 ± .001
XX-7146A	1.701	0.562	0.437	0.110	0.120 ± .001

Figure 10 Instrument/Industrial Configuration

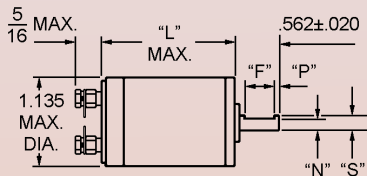

Model #	"L"	"F"	"P"	"N"	"S"
XX-740A	1.701	OMIT	OMIT	OMIT	0.120 ± .001
XX-740B	2.138	OMIT	OMIT	OMIT	0.120 ± .001
XX-780B	2.193	0.375	0.062	0.157	0.187 ± .001
XX-780D	3.253	0.375	0.062	0.157	0.187 ± .001
XX-797A	1.701	0.187	0.187	0.110	0.120 ± .001
XX-7103A	1.756	0.375	0.062	0.157	0.187 ± .001
XX-7107D	3.253	OMIT	OMIT	OMIT	0.187 ± .001
XX-7123A	1.756	OMIT	OMIT	OMIT	0.187 ± .001
XX-7123B	2.193	OMIT	OMIT	OMIT	0.187 ± .001
XX-7356F	1.701	OMIT	OMIT	OMIT	0.120 ± .001
XX-7360F	1.756	0.375	0.062	0.157	0.187 ± .001

Figure 11 Industrial Configuration

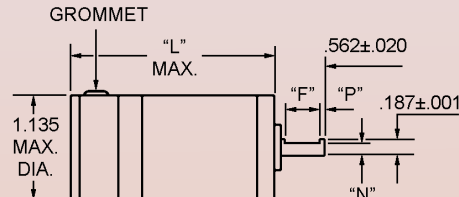

Model #	"L"	"F"	"P"	"N"
XX-757A	2.240	0.375	0.062	0.157
XX-757B	2.677	0.375	0.062	0.157
XX-796B	2.677	OMIT	OMIT	OMIT
XX-7483H	2.677	0.375	0.062	0.157

Figure 12 E-Series Tachometers

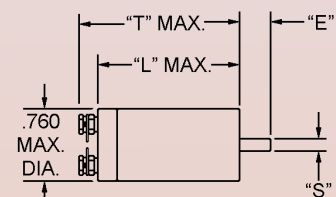

Model #	"T"	"L"	"E"	"S"
SS-779E	1.687	1.479	0.375 ± .015	0.1200 ± .0005
SS-7251E	1.687	1.479	0.562 ± .015	0.1870 ± .0002

Servo-Tek Products Company • 1086 Goffle Road • Hawthorne, NJ 07506
 Phone (973) 427-3100 • Fax (973) 427-4249 • www.servotek.com
 Specifications subject to change without notice
 Copyright © 2003 Servo-Tek Products Company