

	TYPE M1-MINI	TYPE M2-STANDARD
FILTERS		
Port Size	1/8, 1/4 NPT	1/4, 3/8, 1/2 NPT
Filtration (micron)	5μ, 25μ, 50μ	5μ, 25μ, 50μ
Maximum Supply Pressure	1.0 MPa	1.0 MPa
	10 BAR	10 BAR
	145 psi	145 psi
Temperature Range	41°-140° F / 5°-60° C	41°-140° F / 5°-60° C
Drain	Manual / Semi-Auto	Manual / Semi-Auto / Auto
Bowl Capacity	0.75 inch ³	2.75 inch ³
Flow (based on 100 psi inlet pressure with 50 micron filter)	55, 85 SCFM	120, 120, 120 SCFM
REGULATORS		
Effect of Supply Pressure variation (25 psig) on Outlet Pressure	< 0.2 psig (13.8 mBAR)	< 0.2 psig (13.8 mBAR)
Exhaust Capacity (5 psig above 20 psig set point)	< 0.25 SCFM (< 7 LPM)	< 0.25 SCFM (< 7 LPM)
Max. Supply Pressure	145 psig (10 BAR)	145 psig (10 BAR)
Flow Capacity at 100 psig (6.9 BAR) supply and 70 psig (4.8 BAR) outlet	40, 60 SCFM	90, 120, 120 SCFM
Output Pressure Ranges	0-10 psig (0-0.69 BAR)	0-10 psig (0-0.69 BAR)
	0-30 psig (0-2.1 BAR)	0-30 psig (0-2.1 BAR)
	0-60 psig (0-4.1 BAR)	0-60 psig (0-4.1 BAR)
	0-120 psig (0-8.3 BAR)	0-120 psig (0-8.3 BAR)
Total Air Consumption @ Maximum Output	0.3 SCFH (0.14 LPM)	0.3 SCFH (0.14 LPM)
Port Size	1/8, 1/4 NPT	1/4, 3/8, 1/2 NPT
Mounting Options	Pipe, Panel or Bracket	Pipe, Panel or Bracket
FILTER-REGULATORS		
Port Size	1/8, 1/4 NPT	1/4, 3/8, 1/2 NPT
Filtration (micron)	5μ, 25μ, 50μ	5μ, 25μ, 50μ
Maximum Supply Pressure	1.0 MPa	1.0 MPa
	10 BAR	10 BAR
	145 psi	145 psi
Temperature Range	41°-140° F / 5°-60° C	41°-140° F / 5°-60° C
Drain	Manual / Semi-Auto	Manual / Semi-Auto / Auto
Bowl Capacity	0.75 inch ³	2.75 inch ³
Regulator Output Range	0-10, 0-30, 0-60, 0-120 psi	0-10, 0-30, 0-60, 0-120 psi
Flow (based on 100 psi supply/70 psi out)	40, 60 SCFM	90, 120, 120 SCFM
LUBRICATORS		
Port Size	1/8, 1/4 NPT	1/4, 3/8, 1/2 NPT
Lubrication	Mist	Mist
Maximum Supply Pressure	1.0 MPa	1.0 MPa
	10 BAR	10 BAR
	145 psi	145 psi
Temperature Range	41°-140° F / 5°-60° C	41°-140° F / 5°-60° C
Bowl Capacity	1.22 inch ³	5.18 inch ³
Flow (based on 100 psi inlet pressure)	55, 115 SCFM	125, 125, 125 SCFM

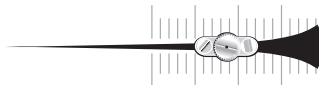

FRL FEATURES

Modular design for service & interchangeability

Miniature (M1), Standard (M2)

Small package size and light weight construction

Competitively priced

FILTERS

M1 has polycarbonate bowl, M2 have polycarbonate bowl with metal guard

STOCK ELEMENTS - 5, 25 or 50 micron

Manual, semi-auto or auto drain available

REGULATORS

Bellofram® Rolling Diaphragm for superior regulator performance

Panel, pipe, or bracket (included) mounting

Metal body, polycarbonate bonnet and knob

Non-rising adjustment knob with push-pull lock ring feature

FILTER REGULATORS

Aluminum and polycarbonate construction

Manual, semi-auto or autodrain available

M1 has polycarbonate bowl; M2 has polycarbonate bowl with metal guard

Non-rising adjustment knob with push-pull lock ring feature

For panel or bracket mounting

Bellofram® Rolling Diaphragm for superior regulator performance

LUBRICATORS

M1 has polycarbonate bowl; remove bowl for filling.

M2 has polycarbonate bowl with metal guard; top plug permits filling without removing bowl or shutting off air

Adjust drip rate by hand, using graduated ring on M1, with screwdriver on M2

FRL ORDERING INFORMATION

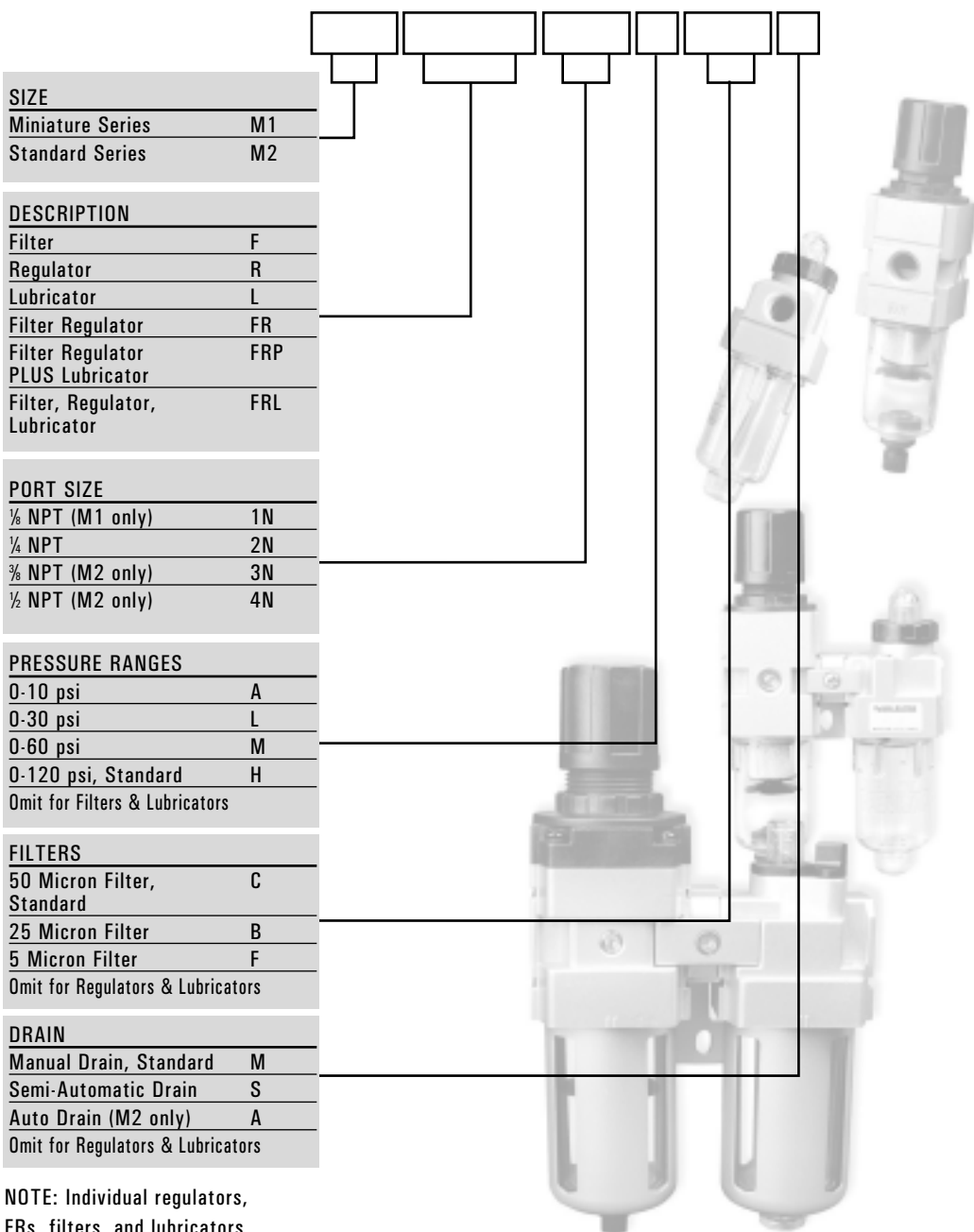

NOTE: Individual regulators, FRs, filters, and lubricators come complete with bracket. FRL assemblies come complete with all bracket/connectors.



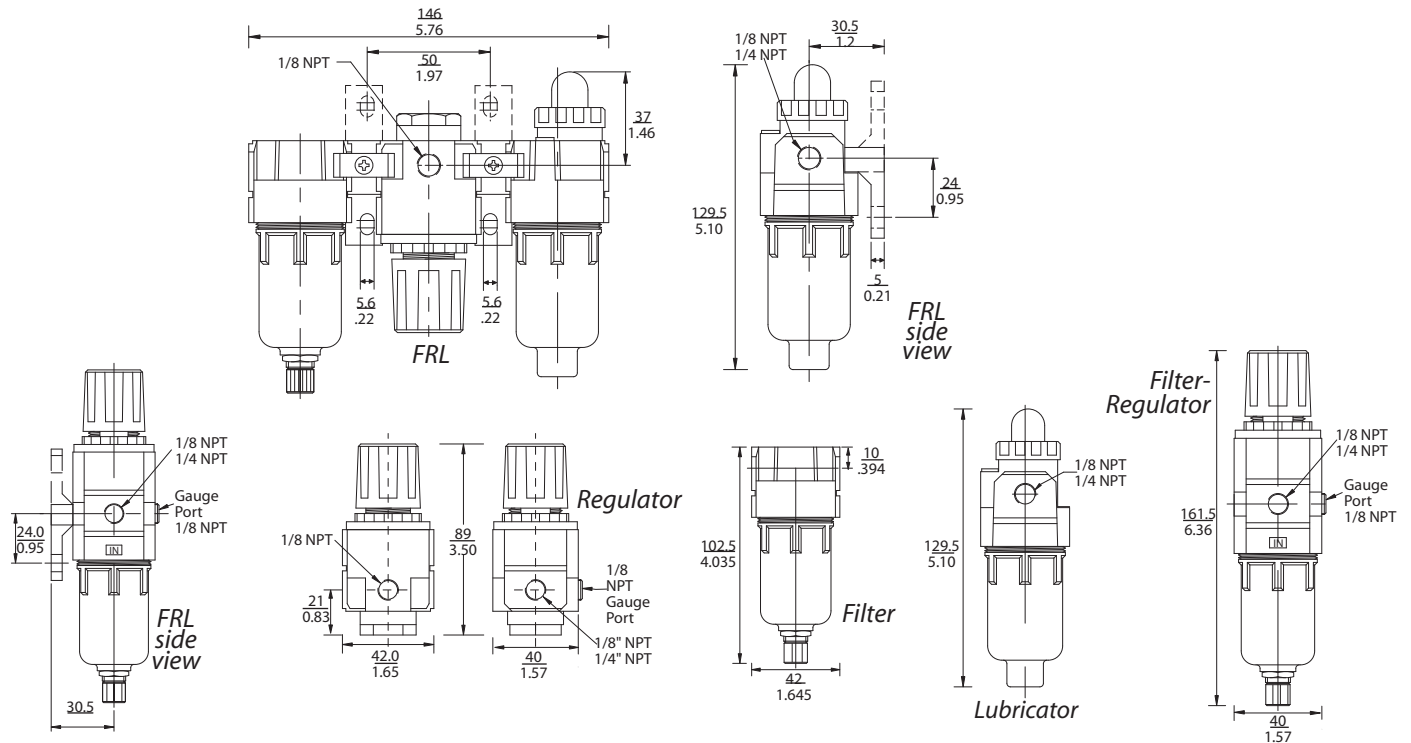

TYPE M1

Weight: 1 lb.

ALL DIMENSIONS ARE NOMINAL

TYPE M2

Weight: 2 lb.

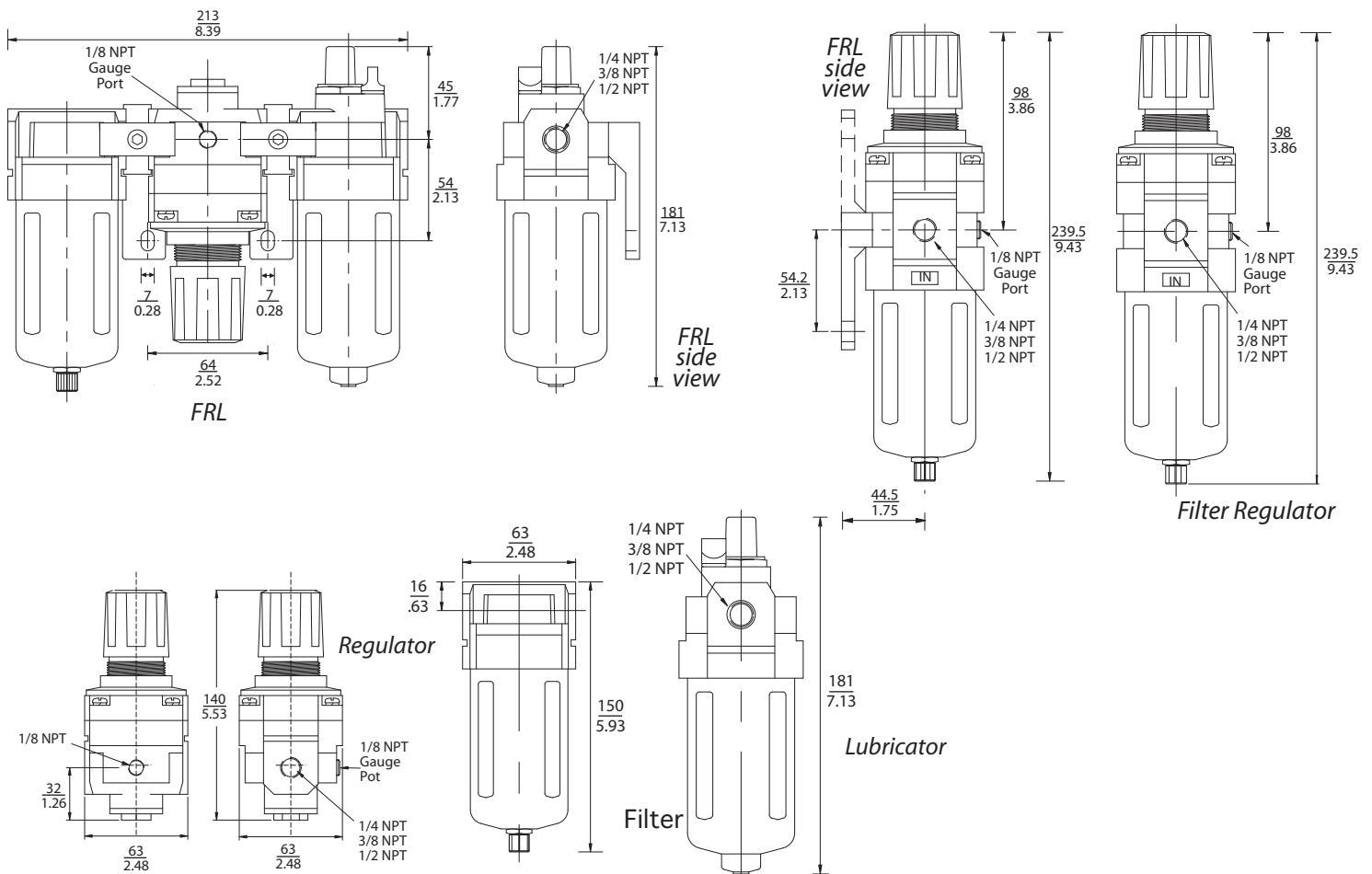

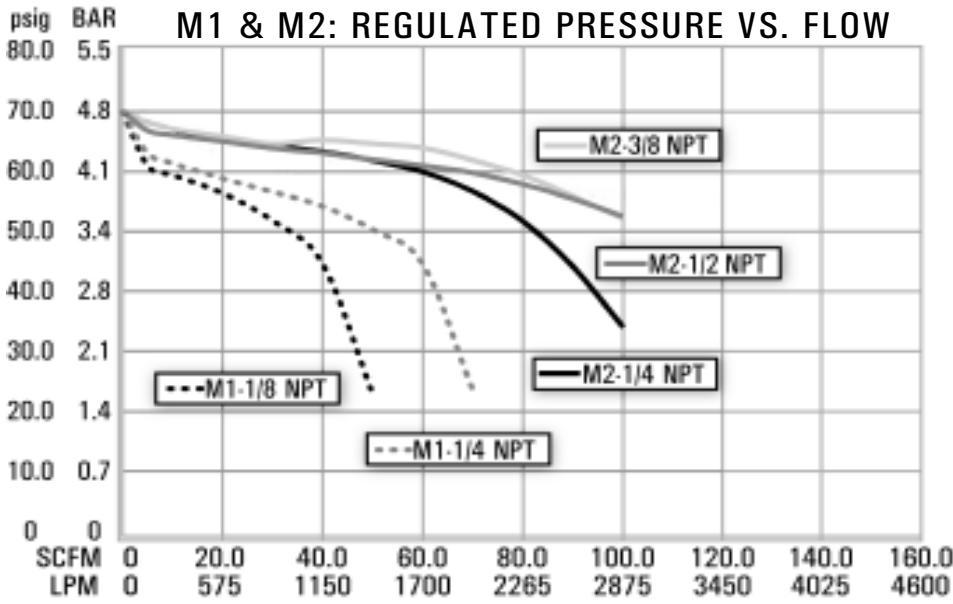
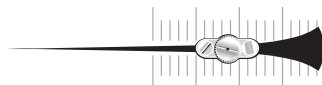

REPLACEMENT PARTS



Description	Model #
Miniature Size Connector Kit	M1K
Miniature Size Connector Kit FR+L	M1K2
Standard Size Connector Kit	M2K
Standard Size Connector Kit FR+L	M2K2



Miniature Size Filter or Lubricator Bracket	M1FB
Standard Size Filter or Lubricator Bracket	M2FB
Miniature Size Regulator or Filter Regulator Bracket	M1RB
Standard Size Regulator or Filter Regulator Bracket	M2RB

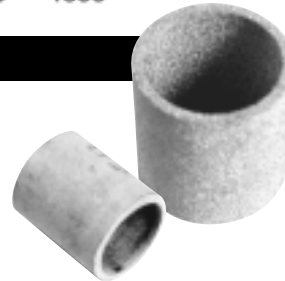

Description	Model #
Miniature 5 micron Filter Element	M1FK05
Miniature 25 micron Filter Element	M1FK25
Miniature 50 micron Filter Element	M1FK50
Standard 5 micron Filter Element	M2FK05
Standard 25 micron Filter Element	M2FK25
Standard 50 micron Filter Element	M2FK50



Miniature Bowl / Manual Drain Assembly	M1DM
Miniature Bowl / Semi-Automatic Drain Assembly	M1DSA
Standard Bowl / Manual Drain Assembly	M2DM
Standard Bowl / Semi-Automatic Drain Assembly	M2DSA
Standard Bowl / Automatic Drain Assembly	M2DA

Pressure Gauges - "GG" Series Gauges pg. 9

