



BelGAS[™]
Needle Valves



BelGAS Standard Needle Valves offer four choices in 316 stainless steel as well as one piece forged carbon plated steel; soft seat and hard seat, angle and globe styles. The Mini valve offers 2 choices in 316 stainless steel and bar stock plated carbon steel; soft seat and hard seat globe style, T-bar and thumb wheel operation.

These valves are suited for instrumentation, process plant use, oil and gas production and general applications where isolation and positive shutoff is a requirement.

For applications requiring a positive shutoff, the soft seat style with Delrin® seat insert offers a bubble tight seat for leak free operation. For corrosives and caustic applications, the hard seat style offers a metal to metal sealing force to clear obstructions and corrosion.

All valves are designed to the following standards;
ANSI B31.1.0 – Power Piping
ANSI B11.20 – Fuel Gas Piping
ANSI B31.3 – Chemical Plant Petroleum Refinery Piping
ASME Section VII-DIV1 – Boiler & Pressure Vessel Code

Thread & Dimensional codes include;
ANSI B2.1 – Pipe Threads
ANSI B1.1 – Straight Threads
ASME B16.10

BelGAS Metal-to-Metal Seat Needle Valves

316 Stainless Steel and Alloy Steel

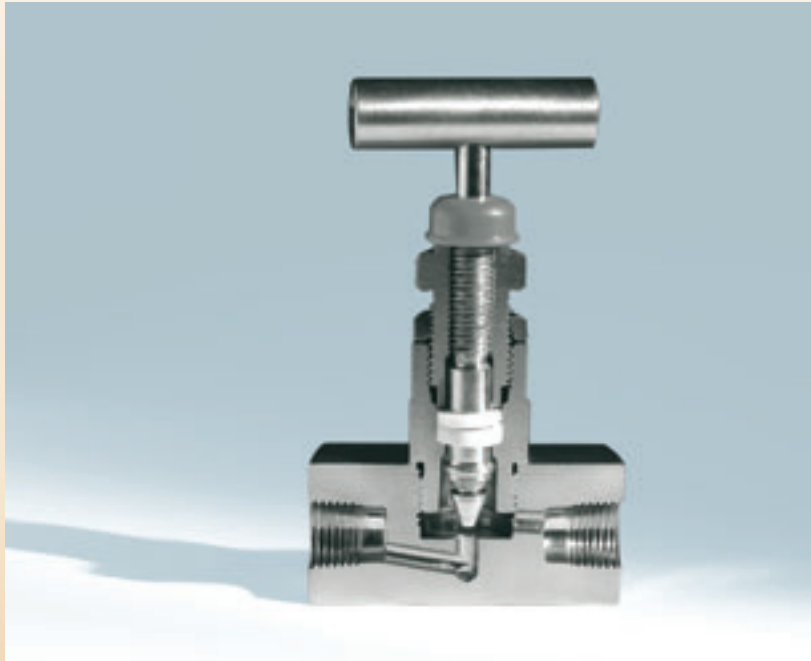

These 316 Stainless steel valves are ideally suited for applications when caustic and corrosive material are being used. Pressure ratings to 10,000 psi (70,000 kPa).

- "T" bar handle
- Teflon* packing
- Roll-formed stem threads
- Precision-machined stem
- Bonnet locking pin prevents accidental removal
- Below stem thread packing gland
- Hardened and ground self centering, non-rotating tip
- Metal-to-metal seat
- Pressure rating, 10,000 psi (70,000 kPa)

Specifications and Description

Body and Bonnet Material

ASTM A182F 316 stainless steel or ASTM A105 forged single piece steel, plated.

Stem Material

316 stainless steel.

Pressure/Temperature Rating

10,000 psi (70,000 kPa)
@ 100°F [37°C]

4000 psi (28,000 kPa)
@ 500°F [260°C]

Optional Graphite Packing (HT)
10,000 psi (70,000 kPa)
@ 400°F 204°C]

Alloy steel 1500 psi (10,400 kPa)
@ 850°F [460°C]

316 stainless steel
1500 psi (10,400 kPa)
@ 1000°F [538°C]

Packing

Two piece molded Teflon* (PTFE).

Seat

Metal-to-metal.

Handle

"T" bar; 316 stainless steel or ASTM A108 alloy steel

Connection

National Pipe Thread, meeting specifications of ANSI B2.1.

Finish

Stainless steel is passivated. Alloy steel has a clear zinc dichromate finish.

Stem Retaining Method

All valves feature integral back-seated stem for preventing accidental removal.

Assembly

Bonnet is threaded into body and pinned into place.

* Teflon is a registered trademark of DuPont.

** NACE valves are manufactured of 316 SS.

Pattern	Size NPT	Part Number		C _v
		316 SST	Carbon	
FFG	1/8"	VHS-FFG-18	VHC-FFG-18	0.40
	1/4"	VHS-FFG-14	VHC-FFG-14	0.40
	3/8"	VHS-FFG-38	VHC-FFG-38	0.90
	1/2"	VHS-FFG-12	VHC-FFG-12	1.10
	3/4"	VHS-FFG-34	VHC-FFG-34	2.30
	1"	VHS-FFG-01	VHC-FFG-01	3.50
MFG	1/4"	VHS-MFG-14	VHC-MFG-14	0.40
	1/2"	VHS-MFG-12	VHC-MFG-12	1.20
	3/4"	VHS-MFG-34	VHC-MFG-34	2.30
	3/4" x 1/2"	VHS-MFG-3412	VHC-MFG-3412	1.90
FFA	1/8"	VHS-FFA-18	VHC-FFA-18	0.70
	1/4"	VHS-FFA-14	VHC-FFA-14	0.80
	3/8"	VHS-FFA-38	VHC-FFA-38	1.60
	1/2"	VHS-FFA-12	VHC-FFA-12	2.20
	3/4"	VHS-FFA-34	VHC-FFA-34	2.20
MFA	1"	VHS-FFA-01	VHC-FFA-01	2.20
	1/4"	VHS-MFA-14	VHC-MFA-14	0.60
	1/2"	VHS-MFA-12	VHC-MFA-12	1.50

Option	Suffix
Graphite Packing - High Temp.	H
NACE**	N
Panel Mount	P



BelGAS Soft-Seat Needle Valves

316 Stainless Steel and Alloy Steel

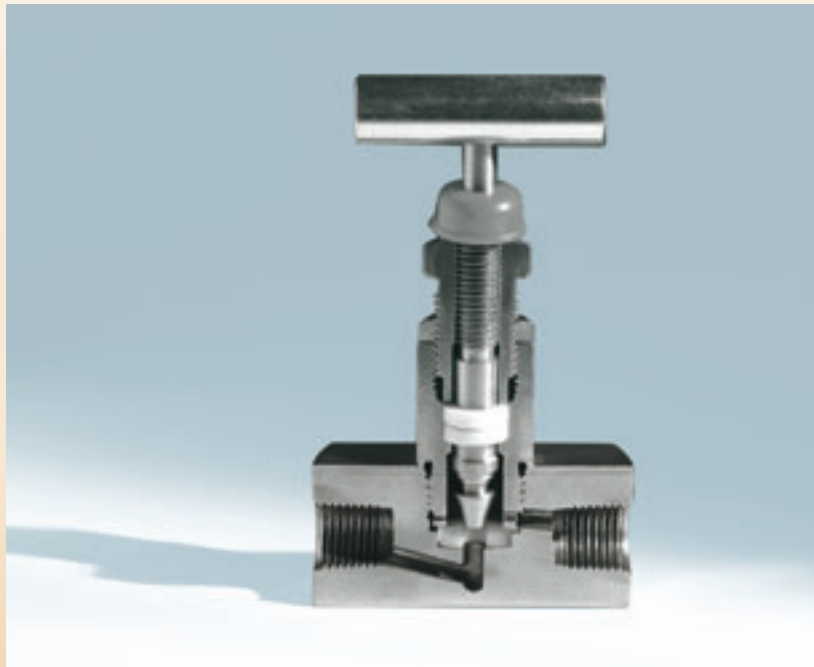

For applications where bubble-tight shutoff of liquids or gases are required. Pressure rating to 6,000 psi (42,000 kPa). These valves are designed with a replaceable Delrin** soft seat.

- "T" bar handle
- Teflon* packing
- Roll-formed stem threads
- Precision-machined stem
- Bonnet locking pin prevents accidental removal
- Below stem thread packing gland
- Hardened and ground self-centering, non-rotating tip
- Soft-seat
- Bubble-tight shutoff of liquids or gases to 6,000 psi (42,000 kPa)

Specifications and Description

Body and Bonnet Material

ASTM A182F 316 stainless steel or ASTM A105 forged single piece steel, plated.

Stem Material

316 stainless steel

Pressure/Temperature Rating

6000 psi (42,000 kPa)
@ 100°F [37°C]

4000 psi (28,000 kPa)
@ 500°F [260°C]

Optional Graphite Packing (HT)
6000 psi (42,000 kPa)
@ 400°F [204°C]

Alloy steel 1500 psi (10,400 kPa)
@ 850°F [460°C]

316 stainless steel
1500 psi (10,400 kPa)
@ 1000°F [538°C]

Packing

Two piece molded Teflon* (PTFE).

Seat

Delrin** Soft-Seat.

Handle

"T" bar; 316 stainless steel or ASTM A108 alloy steel

Connection

National Pipe Thread, meeting specifications of ANSI B2.1.

Finish

Stainless steel is passivated. Alloy steel has a clear zinc dichromate finish.

Stem Retaining Method

All valves feature integral back-seated stem for preventing accidental removal.

Assembly

Bonnet is threaded into body and pinned into place.

* Teflon is a registered trademark of DuPont.

** Delrin is a registered trademark of DuPont.

*** NACE valves are manufactured of 316 SS.

Pattern	Size NPT	Part Number		C _v
		316 SST	Carbon	
FFG	1/4"	VSS-FFG-14	VSC-FFG-14	0.60
	1/2"	VSS-FFG-12	VSC-FFG-12	0.70
	3/4"	VSS-FFG-34	VSC-FFG-34	2.35
	1"	VSS-FFG-01	VSC-FFG-01	2.00
MFG	1/4"	VSS-MFG-14	VSC-MFG-14	0.60
	1/2"	VSS-MFG-12	VSC-MFG-12	0.70
	1/4" x 1/2"	VSS-MFG-1412	VSC-MFG-1412	0.80
MFA	1/4"	—	VSC-MFA-14	0.70
	1/2"	—	VSC-MFA-12	0.70

Option	Suffix
Graphite Packing - High Temp.	H
NACE***	N
Panel Mount	P



Patterns and Dimensions



Metal-to-Metal - 316 Stainless Steel or Alloy

FFG and MFG

Double Female and Male/Female Globe Pattern

Dimension	Nominal Sizes (inches [mm])					
	1/8"	1/4"	3/8"	1/2"	3/4"	1"
A	3.39 [86.0]	3.39 [86.0]	3.46 [88.0]	3.62 [92.0]	3.66 [93.0]	4.41 [112.0]
B		1.18 [30.0]		1.26 [32.0]	1.26 [32.0]	1.69 [43.0]
CF	2.36 [60.0]	2.36 [60.0]	2.68 [68.0]	2.68 [68.0]	2.68 [68.0]	3.15 [80.0]
CM		2.99 [76.0]		3.50 [89.0]	3.50 [89.0]	4.13 [105.0]
E	1.12 [28.5]	1.12 [28.5]	1.26 [32.0]	1.50 [38.0]	1.57 [40.0]	1.77 [45.0]
Orifice	0.17 [4.2]	0.17 [4.2]	0.25 [6.4]	0.28 [7.0]	0.35 [9.0]	0.47 [12.0]

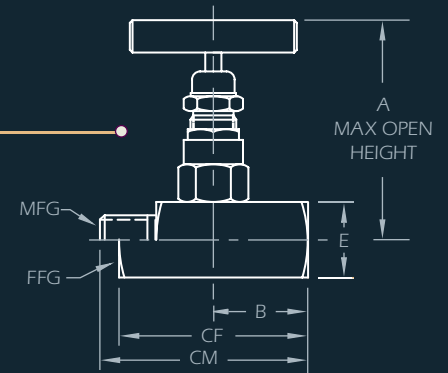

FFA and MFA

Double Female and Male/Female Angle Pattern

Dimension	Nominal Sizes (inches [mm])					
	1/8"	1/4"	3/8"	1/2"	3/4"	1"
A	3.39 [86.0]	3.39 [86.0]	3.39 [86.0]	3.62 [92.0]	3.62 [92.0]	4.41 [112.0]
C	1.65 [42.0]	1.65 [42.0]	1.65 [42.0]	1.97 [50.0]	1.97 [50.0]	2.36 [60.0]
E	1.10 [28.0]	1.10 [28.0]	1.10 [28.0]	1.26 [32.0]	1.42 [36.0]	1.81 [46.0]
F	1.65 [42.0]	1.65 [42.0]	1.65 [42.0]	1.97 [50.0]	1.97 [50.0]	2.36 [60.0]
Orifice	0.17 [4.2]	0.17 [4.2]	0.25 [6.4]	0.28 [7.0]	0.35 [9.0]	0.47 [12.0]

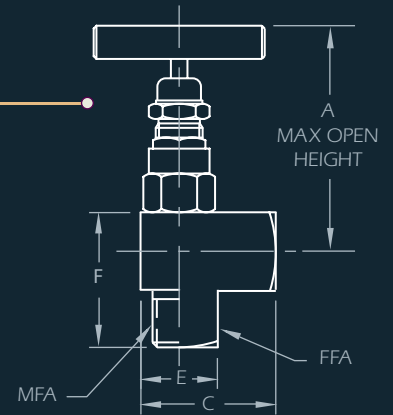

Soft-Seat - 316 Stainless Steel or Alloy

FFG and MFG

Double Female and Male/Female Globe Pattern

Dimension	Nominal Sizes (inches [mm])			
	1/4"	1/2"	1/4" x 1/2"	1"
A	3.39 [86.0]	3.62 [92.0]	3.62 [92.0]	4.41 [112.0]
B	1.18 [30.0]	1.26 [32.0]		1.26 [32.0]
CF	2.36 [60.0]	2.68 [68.0]		3.15 [80.0]
CM	2.99 [76.0]	3.50 [89.0]	3.50 [89.0]	
E	1.12 [28.5]	1.26 [32.0]	1.50 [38.0]	1.77 [45.0]
Orifice	0.17 [4.2]	0.28 [7.0]	0.28 [7.0]	0.47 [12.0]

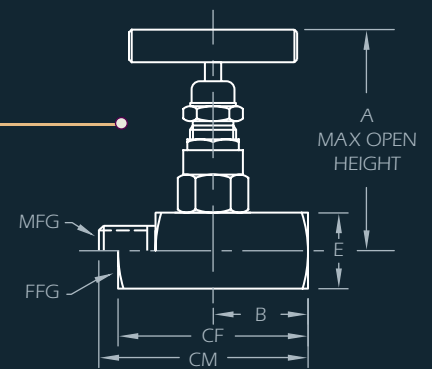

MFA

Male/Female Angle Pattern

Dimension	Nominal Sizes (inches [mm])	
	1/4"	1/2"
A	3.39 [86.0]	3.62 [92.0]
C	1.65 [42.0]	1.97 [50.0]
E	1.10 [28.0]	1.26 [32.0]
F	1.65 [42.0]	1.97 [50.0]
Orifice	0.17 [4.2]	0.28 [7.0]

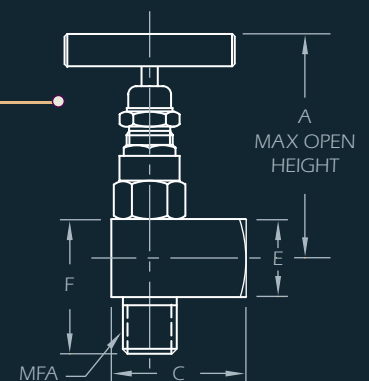

BelGAS Block/Bleed Terminal Needle

316 Stainless Steel and Alloy Steel



Ideally used to isolate gauge legs and gauge reading, allow sampling to take place without loss of material and provide extra pressure ports with isolation capabilities and can be used only when needed.

- "T" bar handle
- Teflon* packing
- Roll-formed stem threads
- Precision-machined stem
- Below stem thread packing gland
- Hardened and ground 316 stainless steel, self-centering, non-rotating tip
- Carbon steel or 316 SST port plug
- Pressure rating, 10,000 psi (70,000 kPa)

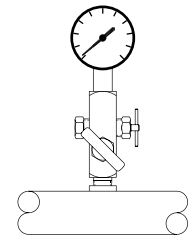
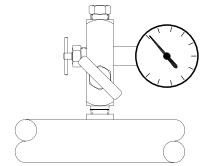

Specifications and Description

Body and Bonnet Material

ASTM A182F 316 stainless steel or ASTM A105 forged single piece steel, plated

Stem Material

316 stainless steel

Pressure/Temperature Rating

10,000 psi (70,000 kPa)
@ 100°F [38°C]

4000 psi (28,000 kPa)
@ 500°F [260°C]

Optional Graphite Packing (HT)
10,000 psi (70,000 kPa)
@ 400°F [204°C]

Alloy steel 1500 psi (10,400 kPa)
@ 850°F [460°C]

316 stainless steel
1500 psi (10,400 kPa)
@ 1000°F [538°C]

Packing

Two piece molded Teflon* (PTFE).

Seat

Metal-to-metal.

Handle

"T" bar; 316 stainless steel or ASTM A108 alloy steel

Connection

National Pipe Thread, meeting specifications of ANSI B2.1.

Finish

Stainless steel is passivated. Alloy steel has a clear zinc dichromate finish.

Stem Retaining Method

All valves feature integral back-seated stem for preventing accidental removal.

Assembly

Bonnet is threaded into body and pinned into place.

* Teflon is a registered trademark of DuPont.

Pattern	Size NPT	Part Number		C _v
		316 SST	Carbon	
Block/Bleed	1/2" x 1/2"	BHC-MFG-12	BHS-MFG-12	0.40
	3/4" x 1/2"	BHC-MFG-3412	BHS-MFG-3412	0.40

Option	Suffix
Graphite Packing - High Temp.	H

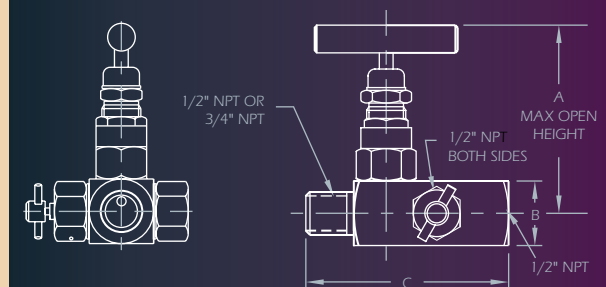

Dimension	Nominal Size (inches [mm])	
	1/2"	3/4" x 1/2"
A	3.54 [90.0]	3.54 [90.0]
B	1.50 [38.0]	1.50 [38.0]
C	3.74 [95.0]	3.74 [95.0]
Orifice	0.28 [7.0]	0.28 [7.0]



BelGAS Miniature Needle Valves

316 Stainless Steel and Alloy Steel

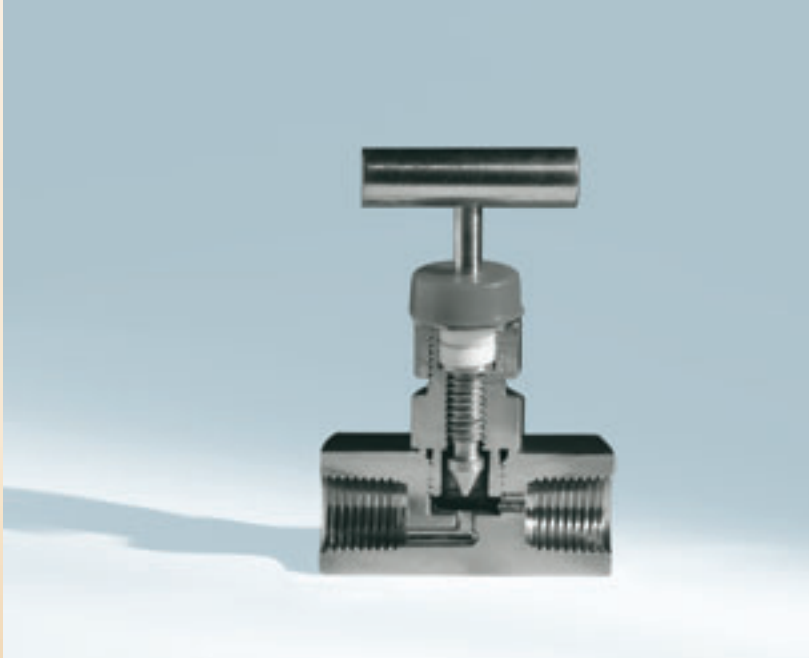

Miniature size for applications where space is limited. Ideal for test stand and general equipment.

- "T" bar handle or thumb wheel
- Roll-formed stem threads.
- Precision-machined stem.
- Teflon* packing
- Bonnet locking pin prevents accidental removal
- Metal-to-metal and soft seat
- Pressure rating, 6,000 psi (42,000 kPa)

Specifications and Description

Body and Bonnet Material

ASTM A479 316 stainless steel or ASTM A108 barstock steel, plated

Stem Material

316 stainless steel

Bonnet Cap (Protective Cover)

Low density polyethylene, red.

Pressure/Temperature Rating

6000 psi (42,000 kPa)
@ 100°F [38°C]

4000 psi (28,000 kPa)
@ 500°F [260°C]

Packing

Molded Teflon* (PTFE).

Seat

Metal-to-metal and Delrin** Soft-Seat.

Handle

"T" bar; 316 stainless steel / ASTM A108 alloy steel / aluminum anodized thumb wheel.

Connection

National Pipe Thread, meeting specifications of ANSI B2.1.

Finish

Stainless steel is passivated. Alloy steel has a clear zinc dichromate finish.

Stem Retaining Method

All valves feature integral back-seated stem for preventing accidental removal.

Assembly

Bonnet is threaded into body and pinned into place.

* Teflon is a registered trademark of DuPont.

** Delrin is a registered trademark of DuPont.

Pattern	Size NPT	Part Number		Seat	C _v
		316 SST	Carbon		
FFG	1/8"	MHS-FFG-18	MHC-FFG-18	Hard	0.25
	1/8"	MHS-FFG-18W	MHC-FFG-18W	Hard	0.25
	1/4"	MHS-FFG-14	MHC-FFG-14	Hard	0.25
	1/4"	MHS-FFG-14W	MHC-FFG-14W	Hard	0.25
MFG	1/4"	MHS-MFG-14	MHC-MFG-14	Hard	0.25
	1/4"	MHS-MFG-14W	MHC-MFG-14W	Hard	0.25
	1/4"	MSS-MFG-14	MSC-MFG-14	Soft	0.25
1/4"	MSS-MFG-14W	MSC-MFG-14W	Soft	0.25	

Standard is T-bar — "W" is thumb wheel

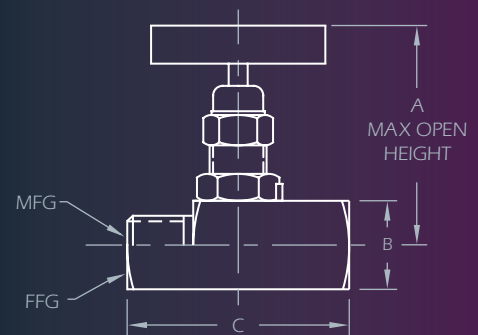

Dimension	Nominal Size (inches [mm])	
	1/8"	1/4"
A	2.44 [62.0]	2.44 [62.0]
B	0.87 [22.0]	0.87 [22.0]
C	1.89 [48.0]	1.89 [48.0]
Orifice	0.13 [3.2]	0.13 [3.2]

Needle Valve Part Number Matrix										
V	S	C	-	F	F	G	-	18	W	Sample Part Number
↑	↑	↑		↑	↑	↑		↑↑	↑	
										Valve Type
V										Standard
M										Mini
B										Block/Bleed
										Seat Design
	S									Soft Seat
	H									Hard Seat
										Body Material
		C								Carbon Steel
		S								316 SS
										Inlet Connection
				F						Female
				M						Male
										Outlet Connection
					F					Female
					M					Male
										Body Pattern
						G				Globe Pattern
						A				Angle Pattern
										Connection Size
								18		1/8" NPT
								14		1/4" NPT
								38		3/8" NPT
								12		1/2" NPT
								34		3/4" NPT
								01		1" NPT
										Options
									H	Graphite Packing - High Temp.
									N	NACE
									P	Panel Mount
									W	Hand Wheel (Mini only)
									V	Viton O-ring, Soft seat Only

Flow Coefficient (C_v)

Method of Calculating Flow: The flow coefficient "C_v" of a valve is the flow rate of water (gallons/minute) through a fully opened valve, with a pressure drop of 1 psi across the valve. To find the flow of liquid through a valve from the flow coefficient (C_v), use the following formula:

$$Q_L = C \sqrt{\frac{\Delta P}{G}}$$

Q_L = flow rate of liquid (gal/min.)

ΔP = differential pressure across the valve (psi)

G = specific gravity of liquid (for water, G = 1)

To find the flow of gas through a valve, use the following formula:

$$Q_g = 61 C_v \sqrt{\frac{P_2 \Delta P}{g}} \left\{ \begin{array}{l} \text{For noncritical flow} \\ \frac{\Delta P}{P_2} \text{ less than } 1.0 \end{array} \right\}$$

Q_g = flow rate of gas (CFH at STP)

P = outlet pressure (psi)

g = specific gravity of gas; g air = 1.0000

IMPORTANT: Flow coefficients are dependent on both the size of the valve and the valve pattern itself. Marsh "C_v" factors give flow information for all sizes and patterns so that the designer is able to provide sufficient flow within the system.